



EP25N - EP25CN - EP30N EP30CN - EP35N

Specifications

Electric-Powered Lift Trucks

2,500 - 3,500 KG



Characteristics			Cat Lift Trucks	Cat Lift Trucks	Cat Lift Trucks	Cat Lift Trucks	Cat Lift Trucks
1.1	Manufacturer (abbreviation)		EP25N	EP25CN	EP30N	EP30CN	EP35N
1.2	Manufacturer's model designation		Electric	Electric	Electric	Electric	Electric
1.3	Power source: (battery, diesel, LP gas, petrol)		Seated	Seated	Seated	Seated	Seated
1.4	Operator type: pedestrian, (operator)-standing, -seated		2500	2500	3000	3000	3500
1.5	Load capacity	Q (kg)	500	500	500	500	500
1.6	Load center distance	c (mm)	476	476	504	504	504
1.8	Load distance, axle to fork face	x (mm)	1730	1585	1730	1585	1730
1.9	Wheelbase	y (mm)					
Weight							
2.1	Truck weight, without load / including battery (simplex mast, lowest lift height)	kg	4700	4621	5152	5234	5591
2.2	Axle loading with maximum load, front/rear (simplex mast, lowest lift height)	kg	6336/864	6332/789	7313/839	7355/878	8186/904
2.3	Axle loading without load, front/rear (simplex mast, lowest lift height)	kg	2424/2275	2292/2329	2571/2581	2454/2780	2654/2937
Wheels, Drive Train							
3.1	Tires: V= Solid, L= pneumatic, SE= solid pneumatic - front/rear		SE	SE	SE	SE	SE
3.2	Tire dimensions, front	pcm/ (mm)	23 x 9 - 10	23 x 9 - 10	23 x 10 - 12	23 x 10 - 12	23 x 10 - 12
3.3	Tire dimensions, rear		18 x 7 - 8	18 x 7 - 8	18 x 7 - 8	18 x 7 - 8	18 x 7 - 8
3.5	Number of wheels, front/rear (x=driven)		2 x / 2	2 x / 2	2 x / 2	2 x / 2	2 x / 2
3.6	Track width (center of tires), front	b10 (mm)	985	985	950	950	950
3.7	Track width (center of tires), rear	b11 (mm)	970	970	970	970	970
Dimensions							
4.1	Mast tilt, forwards/backwards	α/β °	6 / 8	6 / 8	6 / 8	6 / 8	6 / 8
4.2	Height with mast lowered (see tables)	h1 (mm)	2145	2145	2165	2165	2291
4.3	Free lift (see tables)	h2 (mm)	100	100	100	100	100
4.4	Lift height (see tables)	h3 (mm)	3300	3300	3270	3270	3300
4.5	Overall height with mast raised	h4 (mm)	4355	4355	4325	4325	4345
4.7	Height to top of overhead guard	h6 (mm)	2240	2240	2240	2240	2240
4.8	Seat height	h7 (mm)	1130*	1130*	1130*	1130*	1130*
4.12	Tow coupling height	h10 (mm)	395	395	395	395	395
4.19	Overall length	l1 (mm)	3600	3459	3628	3487	3628
4.20	Length to fork face (includes fork thickness)	l2 (mm)	2530	2389	2558	2417	2558
4.21	Overall width	b1/b2 (mm)	1190	1190	1190	1190	1190
4.22	Fork dimensions (thickness, width, length)	s / e / l (mm)	40x100x1070	40x100x1070	45x125x1070	45x125x1070	45x125x1070
4.23	Fork carriage to DIN 15 173, A/B/no		2A	2A	3A	3A	3A
4.24	Fork carriage width	b3 (mm)	1000	1000	1000	1000	1000
4.31	Ground clearance under mast, with load	m1 (mm)	105	105	115	115	115
4.32	Ground clearance at center of wheelbase, with load (forks lowered)	m2 (mm)	122	122	122	122	122
4.33	Working aisle width with 1000 x1200 mm pallets, crosswise	Ast (mm)	3805	3660	3830	3690	3830
4.34a	Working aisle width with 800 x1200 mm pallets, lengthwise	Ast (mm)	3960	3815	3985	3840	3985
4.35	Turning circle radius	Wa (mm)	2064	1920	2064	1920	2064
4.36	Minimum distance between centers of rotation	b13 (mm)	160	160	160	160	160
Performance							
5.1	Travel speed, with/without load	km/h	20/20	20/20	20/20	20/20	18/18
5.2	Lifting speed, with/without load	m/s	0.5/0.65	0.5/0.65	0.45/0.6	0.45/0.6	0.45/0.6
5.3	Lowering speed, with/without load	m/s	0.55/0.5	0.55/0.5	0.5/0.45	0.5/0.45	0.5/0.45
5.5	Rated drawbar pull, with/without load	N	9300/9700	9300/9700	9100/9550	9100/9550	8950/9500
5.6	Maximum drawbar pull, with/without load (5 min short duty)	N	15800/16200	15800/16200	15550/16050	15550/16050	15400/16000
5.7	Gradeability, with/without load	%	15/25	15/25	13/22	13/22	12/20
5.8	Maximum gradeability, with/without load	%	23/38	23/38	20/34	20/33	18/31
5.9	Acceleration time (10 metres) with/without load	s	4.2/3.9	4.2/3.9	4.3/3.9	4.3/3.9	4.4/3.9
5.10	Service brakes (mechanical/hydraulic/electric/pneumatic)		Hydraulic	Hydraulic	Hydraulic	Hydraulic	Hydraulic
Electric Motors							
6.1	Drive motor capacity (60 min. short duty)	kW	2 x 8 kW	2 x 8 kW	2 x 8 kW	2 x 8 kW	2 x 8 kW
6.2	Lift motor output at 15% duty factor	kW	20.8kW	20.8kW	25.5kW	25.5kW	25.5kW
6.3	Battery to DIN 43531/35/36 A/B/C/no		43.536A	43.536A	43.536A	43.536A	43.536A
6.4	Battery voltage/capacity at 5-hour discharge	V/Ah	80 / 700-775	80 / 560-620	80 / 700-775	80 / 560-620	80 / 700-775
6.5	Battery weight	kg	1863	1558	1863	1558	1863
6.6	Energy consumption according to VDI 60 cycle	kWh/h	-	-	-	-	-
Miscellaneous							
8.1	Type of drive control		AC	AC	AC	AC	AC
8.2	Maximum operating pressure for attachments	bar	185	185	185	185	205**
8.3	Oil flow for attachments	l/min	30	30	30	30	30
8.4	Noise level, value at operator's ear (EN 12053)	dB(A)	65	65	66	66	66
8.5	Towing coupling design / DIN type, ref.		DIN15170-H	DIN15170-H	DIN15170-H	DIN15170-H	DIN15170-H

* h7 values recorded with MSG65 seat type.

**Separate option for pressure relief valve when lower pressure needed.



Ast = Working aisle width with load

$$Ast = Wa + \sqrt{(l6 + x)^2 + \left(\frac{b12 - b13}{2}\right)^2} + a$$

Wa = Turning radius

x = Load distance, axle to fork face

l6 = Pallet length

a = Safety clearance

b12 = Pallet width

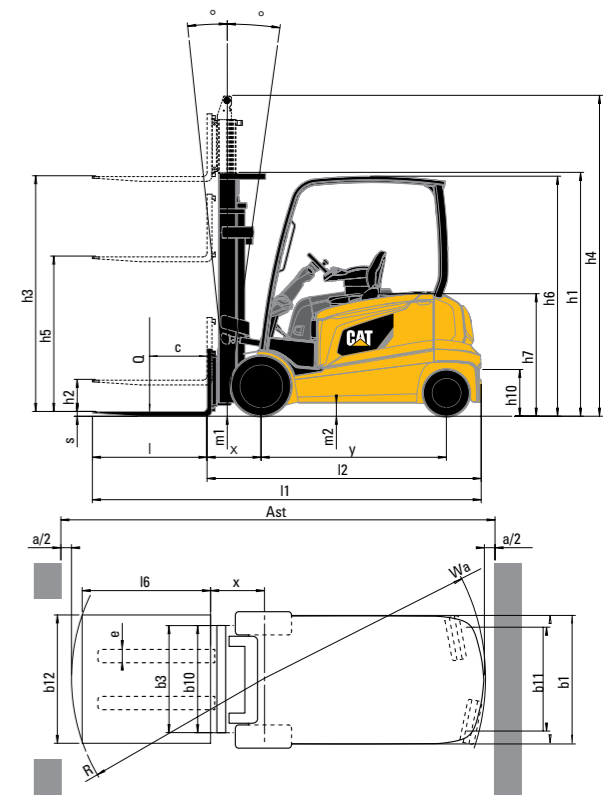

Lower Cost Of Ownership

- Full-color, weather-protected, clear-view display, with information in the operator's language and simple-to-learn functionality, advises on lift truck status, avoids misuse and protects your investment.

Unmatched Productivity

- Responsive Drive System (RDS) with adaptive speed control adjusts truck performance modes in reaction to quickness of foot and fingertip movements, to meet driver's changing needs, and ensures smooth starts and stops.
- Intelligent speed and movement reduction (optional) automatically limits travel and tilt rates when forks are above free lift height, to optimize both stability and agility.
- Intelligent curve control makes speed reduction in cornering feel natural, with no sensation of leaning, for secure but productive driving.
- Twin-mode key switch offers ECO setting for beginners, or for low energy consumption, and PRO for experienced drivers and high performance, while optional customization is available to meet specific needs.
- Next-generation dual-drive 4-wheel steering system, with curve control, +100° rear axle rotation, instant no-push side turns and unique ability to steer using front axle, delivers unbeatably agile maneuvering, better traction and longer tire life.

Safety And Ergonomics

- Completely redesigned and adjustable armrest, combining anatomical support with free movement and perfect hand positioning, features spring-force-optimized fingertip hydraulic controls or an optional intuitive joystick control.
- Armrest options include control of forward/reverse selection, clamp release and automatic tilt centring, using only the driver's fingers.
- Wide, high-grip step, long grab handle and curved lift truck design allow fast, smooth-flowing on-off access to large, comfortable operator space with flat, unobstructed floor.
- Ergonomic layout of controls and display, together with adjustable seat and steering wheel position, optimized pedal angles and excellent all-around view, helps provide strain-free operation.

Options

- Intelligent speed and movement reduction
- Armrest-mounted forward/reverse, clamp release and automatic tilt centring controls
- Joystick hydraulic control
- Operator presence pedal
- Sideways battery change
- Three-stage overload warning system
- Dual accelerator pedal

Cat® Lift Trucks.

Your partner in material handling.

Mast Type	EP25N/EP25CN					EP25N	EP25CN
	h3	h1	h4	h2/h5*	tilt angle	Q @ c = 500mm kg	Q @ c = 500mm kg
	mm	mm	mm	mm	(fwd-rev)		
Simplex	3000	1995	4055	100	6/8	2500	2500
	3300	2145	4355	100	6/8	2500	2500
	3740	2410	4795	100	6/8	2500	2500
	4100	2590	5155	100	6/8	2500	2500
	4500	2800	5555	100	6/8	2500	2500
	5000	3050	6055	100	6/8	2500	2450
	5500	3300	6555	100	6/8	2500	2350
Duplex	3000	1995	4055	940	6/8	2500	2500
	3300	2145	4355	1090	6/8	2500	2500
	3700	2410	4755	1355	6/8	2500	2500
	4020	2590	5075	1535	6/8	2500	2500
Triplex	3730	1805	4785	750	6/6	2500	2500
	4030	1905	5085	850	6/6	2500	2500
	4300	1995	5355	940	6/6	2500	2500
	4750	2145	5805	1090	6/6	2500	2450
	5060	2265	6115	1210	6/6	2500	2400
	5500	2410	6555	1355	6/6	2500	2300
	5990	2590	7045	1535	6/6	2400	2200
	6500	2850	7555	1795	6/6	1900	1950
	7000	3050	8055	1995	6/6	1400	1500

* h5 including load backrest (without load backrest increase with 305 mm duplex or 465 mm triplex)

Mast Type	EP30N/EP30CN					EP30N	EP30CN
	h3	h1	h4	h2/h5*	tilt angle	Q @ c = 500mm kg	Q @ c = 500mm kg
	mm	mm	mm	mm	(fwd-rev)		
Simplex	3030	2045	4085	100	6/8	3000	3000
	3270	2165	4325	100	6/8	3000	3000
	3700	2430	4755	100	6/8	3000	3000
	4000	2610	5055	100	6/8	3000	3000
	4500	2870	5555	100	6/8	3000	3000
	5000	3120	6055	100	6/8	2900	2900
	5500	3370	6555	100	6/8	2700	2700
	6000	3635	7055	100	6/6	2200	1950
	Duplex	3000	2035	4055	980	6/8	3000
3250		2165	4305	1110	6/8	3000	3000
3700		2430	4755	1375	6/8	3000	3000
4010		2610	5065	1555	6/8	3000	3000
Triplex		3690	1825	4745	770	6/6	3000
	3990	1925	5045	870	6/6	3000	3000
	4320	2045	5375	990	6/6	3000	3000
	4700	2165	5755	1110	6/6	2900	3000
	5060	2285	6115	1230	6/6	2850	3000
	5450	2430	6505	1375	6/6	2750	3000
	5970	2610	7025	1555	6/6	2600	2600
	6470	2870	7525	1815	6/4	2200	1900
	7000	3070	8055	2015	6/4	1600	1350

Mast Performance and Capacity

- h1 Height with mast lowered
- h2 Standard free lift
- h3 Lift height
- h4 Height with mast raised
- h5 Full free lift
- Q Lifting capacity, rated load
- c Load center (distance)

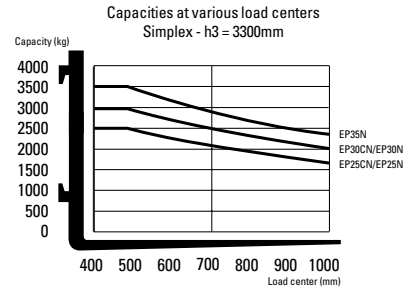

Battery Dimensions

		EP25N	EP25CN	EP30N	EP30CN	EP35N
Battery Voltage	V	80	80	80	80	80
Capacity at 5-hour discharge	Ah	700-775	560-620	700-775	560-620	700-775
Battery weight (+/-5%)	kg	1863	1558	1863	1558	1863
Battery box dimensions						
Length	mm	1028	1028	1028	1028	1028
Width	mm	855	711	855	711	855
Height	mm	784	784	784	784	784
Battery compartment size						
Length	mm	1056	1056	1056	1056	1056
Width	mm	865	720	865	720	865
Height*	mm	790	790	790	790	790

*5mm tolerance

Mast Type	EP35N					
	h3	h1	h4	h2/h5*	tilt angle	Q @ c = 500mm kg
	mm	mm	mm	mm	(fwd-rev)	
Simplex	3000	2170	4045	100	6/8	3500
	3300	2290	4345	100	6/8	3500
	3720	2500	4765	100	6/8	3500
	4000	2755	5045	100	6/8	3500
	4500	3000	5545	100	6/8	3500
	5000	3250	6045	100	6/8	3300
	5500	3500	6545	100	6/6	3000
	6000	3750	7045	100	6/6	2200
	Duplex	3010	2170	4055	1125	6/8
3300		2290	4345	1245	6/8	3500
3720		2615	4765	1570	6/8	3500
4000		2755	5045	1710	6/8	3500
Triplex		3730	1930	4775	885	6/6
	4010	2050	5055	1005	6/6	3500
	4390	2170	5435	1125	6/6	3500
	4700	2290	5745	1245	6/6	3400
	5030	2435	6075	1390	6/6	3300
	5580	2615	6625	1570	6/6	3200
	6000	2755	7045	1710	6/4	2800
	6510	2930	7555	1885	6/4	2000
	7000	3125	8045	2080	6/4	1550

www.cat-lift.com

CESC1606(07/14)

©2014, MCFE. All Rights Reserved. CAT, CATERPILLAR, BUILT FOR IT, their respective logos, "Caterpillar Yellow," the "Power Edge" trade dress as well as corporate and product identity used herein, are trademarks of Caterpillar and may not be used without permission.

NOTE: Performance specifications may vary depending on standard manufacturing tolerances, vehicle condition, types of tires, floor or surface conditions, applications, or operating environment. Trucks may be shown with non-standard options. Specific performance requirements and locally available configurations should be discussed with your Cat lift trucks Dealer. Cat Lift Trucks follows a policy of continual product improvement. For this reason, some materials, options and specifications could change without notice.

