

- Automatic, reliable and secure
- Optimized transport routes
- Utilization of existing routes
- Short payback period
- Flexibility thanks to adjustable forks



EKS 215a

Automated Guided Vehicle (AGV) Medium/High Level Order Picker / Stacker (3,300 lb.)

The EKS 215a is an automated guided vehicle system based on our vertical order pickers. It combines tried-and-tested mechanical engineering with innovative automation, including accurate navigation technology. This helps ensure reliable and efficient production.

The EKS 215a can be used in mixed operations mode with manual trucks and pedestrians. Whether to be integrated into existing factory structures or a new build – the EKS 215a is the perfect choice for increasing the efficiency of your transport processes. The adjustable forks mean that the EKS 215a is also ideally equipped for the transport of special load carriers and closed pallets.

The Jungheinrich AGV is navigated by means of laser navigation. No floor work is required. For the laser navigation, reflectors are attached to suitable objects along the travel route such as racking, columns and walls or natural landmarks.

The AGV can easily be integrated into the existing IT and software landscape. Our award-winning Jungheinrich Logistics Interface facilitates a smooth connection to any host system, such as the Jungheinrich Warehouse Management System (WMS) or other available WMS/ERP systems. However, the AGV can also be used as a stand-alone system, i.e. as an autonomous system without a host connection.

The modular system structure makes it possible to represent individual customer processes as well as reacting flexibly and quickly to process changes. This creates a solid basis for the use of the AGV system according to your specific requirements.

EKS 215a

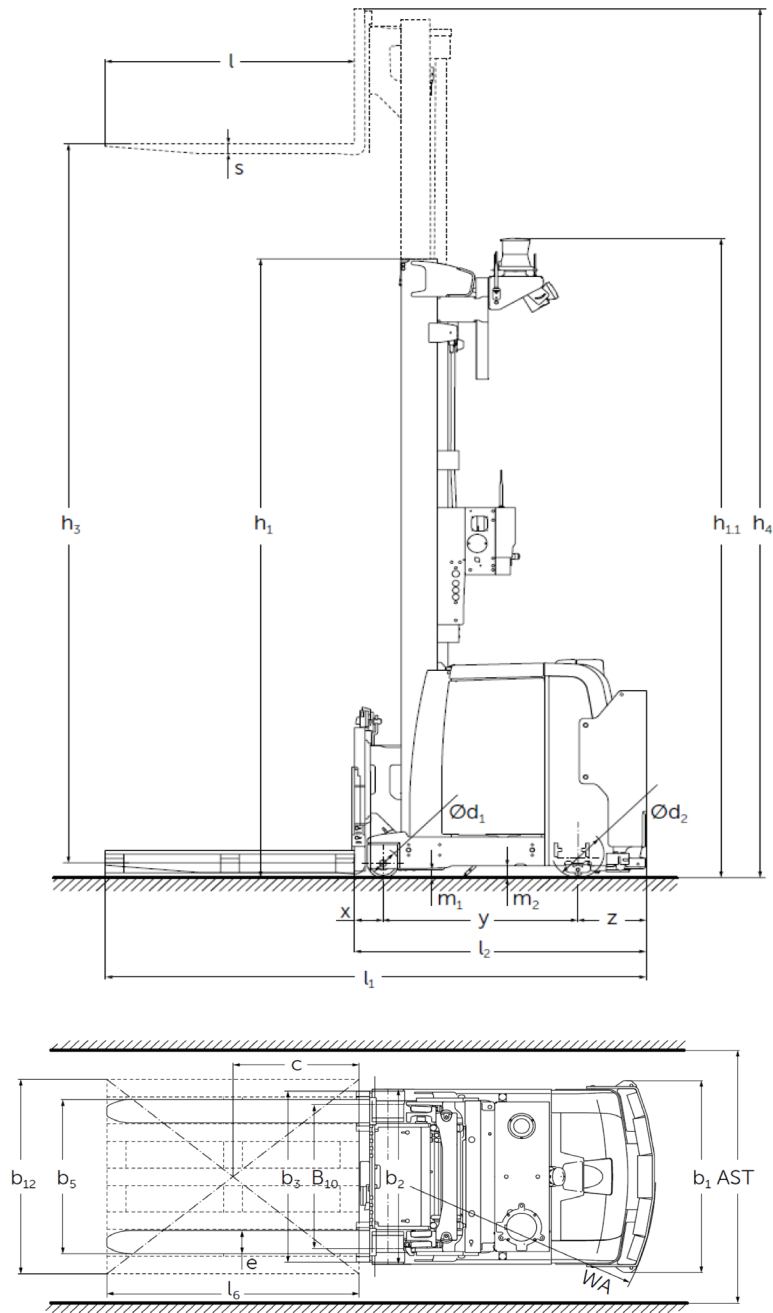

Mast Types								
	Maximum Fork Height		Lowered Mast Height (incl. scanner)		Lowered Mast Height		Extended Mast Height	
	h_3		$h_{1.1}$		h_1		h_4	
	in	mm	in	mm	in	mm	in	mm
Duplex ZT	137	3,500	102	2,585	98	2,475	169	4,280
	157	4,000	112	2,835	108	2,725	189	4,780
	196	5,000	132	3,335	127	3,225	228	5,780
	236	6,000	151	3,835	147	3,725	267	6,780

Technical data

as of: 01/2019

Characteristics	1.1	Manufacturer			Jungheinrich						
	1.2	Model			EKS 215a						
	1.3	Drive			electric						
	1.4	Type of operation			AGV						
	1.5	Load capacity / rated load	Q	lb	kg	3,300	1,500				
	1.6	Load center distance	c	in	mm	24.0	600				
	1.8	Load distance (load axle to fork face)	x	in	mm	5.9	150				
	1.9	Wheelbase	y	in	mm	36.9	938				
	1.10	Center of drive wheel to counterweight	z	in	mm	13.0	330				
	Weights	2.1	Service weight including battery			lb	kg	6,923	3,140		
2.3		Axle loading, no load, front / rear			lb	kg	3,263	3,968	1,480	1,800	
Wheels, Chassis	3.1	Tires			Vulkollan®						
	3.2	Tire size (load wheels)	d ₁	in	mm	5.9 x 3.7	150 x 95				
	3.3	Tire size (drive tire)	d ₂	in	mm	9.8 x 3.1	250 x 80				
	3.5	Wheels, number, front / rear (x=drive wheel)			2 / 1x						
	3.6	Track width	b ₁₀	in	mm	29.1	740				
	Dimensions	4.2	Lowered mast height			h ₁	in	mm	see mast table		
4.4		Maximum fork height			h ₃	in	mm	see mast table			
4.5		Extended mast height			h ₄	in	mm	see mast table			
4.19.2		Total length (without load)			l ₁	in	mm	102.6	2,605		
4.20		Length to fork face (headlength)			l ₂	in	mm	55.3	1,405		
4.21		Overall width			b ₁ / b ₂	in	mm	38.8	35.4	985	900
4.22		Fork dimensions – thickness x width x length			s / e / l	in	mm	1.97 x 4.72 x 47.24	50 x 120 x 1,200		
4.24		Fork carriage width			b ₃	in	mm	34.6	880		
4.25		Overall fork width			b ₅	in	mm	31.9	810		
4.31		Ground clearance under mast (loaded)			m ₁	in	mm	1.6	40		
4.32	Ground clearance at center of wheelbase			m ₂	in	mm	2.4	60			
Performance	5.1	Travel speed, loaded / no load			mph	km/h	4.3 ¹⁾	5.6 ²⁾	7.0 ¹⁾	9.0 ²⁾	
	5.2	Lift speed, loaded / no load			fpm	m/s	57.1	61.0	0.29	0.31	
	5.3	Lowering speed, loaded / no load			fpm	m/s	66.9	61.0	0.34	0.31	
	5.10	Brakes – service Brakes – parking			reverse current / regenerative electric spring loaded						
Electrical	6.1	Drive motor rating S ₂ 60 min.			HP	kW	4.0	3.0			
	6.2	Lift motor rating at S ₃ 15%			HP	kW	12.7	9.5			
	6.3	Battery compartment size – l x w x h			in	mm	consult factory				
	6.4	Battery voltage			Volts	Ah	48	465			
	6.5	Battery weight, minimum / maximum			lb	kg	consult factory				
Other	8.1	Type of drive control			AC control						
	8.4	Sound level at driver's ear			dB(A)	62					
	8.6	Steering			electric						

1) Travel speed in load direction 3.1 / 3.7 mph (5.0 / 6.0 km/h)

The Jungheinrich Advantage

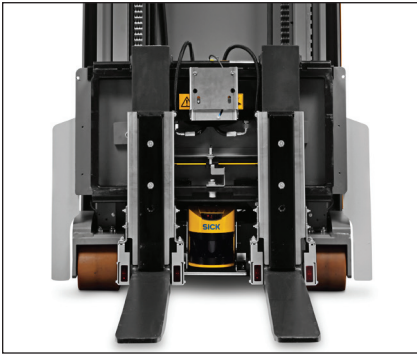

Cross-series benefits

The basis of the EKS 215a is the electric vertical order picker, a tried-and-tested standard truck combined with automation and navigation components. In addition to reliability and efficiency, the EKS 215a also possesses other advantages of the basic truck:

- 48 V three-phase technology for long periods of use without the need to charge the battery.
- Active energy and battery management.
- Energy recovery during lowering and braking.
- Wear-free inversion brake.
- TÜV-certified control system (CAN bus).

Navigation system

The EKS 215a is equipped as standard with a personal protection scanner in the drive and load direction. In line with the speed of the truck, these sensors scan the travel route in front of the AGV for obstacles. Should an obstacle be located in the path of the truck, the AGV will come to a stop in front of it. In addition, the sensor also scans ahead for obstacles when cornering. The standard system is completed with side sensors – for safeguarding the sides of the truck – as well as emergency disconnects on the truck.

Numerous additional system enhancements

By using adjustable forks, the EKS 215a can also pick up closed load carriers and transverse pallets, as well as operate at stations which cannot be driven under.

Easy integration into existing systems

The AGV can easily be integrated into your existing IT and network landscape. Use of the existing WLAN structure is preferable for the communication of the EKS 215a. If an existing host system, such as the Jungheinrich WMS or another WMS/ERP system, is to be used, the AGV can be connected to this system via the Logistics Interface.

Everything at a glance – with the AGV control panel

The graphical visualization on the AGV control panel, displays all the information relating to the AGV in use:

- Quick overview of the status of the AGV system.
- Prioritized orders can be entered and processed in the corresponding order.
- Depending on the project-specific requirements, individual customer functions can be specially implemented and activated for the respective system.

Precise navigation

High degree of precision allows for pinpoint accuracy in the positioning of trucks and loads at defined stations. If necessary, different navigation types can be used as hybrid navigation for the EKS 215a, as with the other AGV models. These are designed and specified according to project and environment.

Additional equipment

Additional equipment options are available for the EKS 215a on a project-specific basis:

- Floor spot.
- Barcode scanner.
- Obstacle detection scanner.
- Sensors for detecting faulty pallets.

Lithium-ion technology (optional)

- High utilization thanks to extremely short charging times.
- No battery exchange required.
- Cost savings due to longer service life and low maintenance compared with lead-acid batteries.
- No charging rooms and ventilation required as there is no build up of gas.

Parts when you need them

Jungheinrich's Parts Fast or Parts Free Guarantee ensures next-business-day delivery by 5:00 PM of all Jungheinrich parts in the United States, or they're free, including freight. For customers in Canada and Mexico, the guarantee ensures shipping of parts within 24 hours from the time the order was placed by the dealer. See your local Jungheinrich dealer for program details.

* Programs may be subject to change without notice and may vary by region. Please ask your local Jungheinrich dealer for complete terms and conditions.