

24 Volt 3-phase AC technology for high performance and excellent reliability

Access via key or easyACCESS soft key/PIN code and 2-inch full color display (optional)

Extremely maneuverable, especially in tight spaces, with its shorter chassis and 15.3% less steering effort required

Excellent travel stability with optional ProTracLink caster system

New design includes a more robust, optimized load frame and pallet entry rollers/discs, designed to promote easier pallet entry, with exit rollers being standard



EJE 120 / EJE 225

Electric Walkie Pallet Truck (4,500 - 6,000 lbs.)

The EJE electric walkie pallet trucks are specifically suited for loading and unloading trailers as well as transporting loads over short and medium distances. Both the EJE 120 and 225 come with a medium battery compartment without cover as standard. A small battery compartment is also available for the EJE 120.

Jungheinrich's innovative 3-phase AC drive motor technology, now up to 23% more efficient than previous generations, provides powerful acceleration and a maximum speed of 3.5 mph, even under a full load. In addition, the sealed AC drive motor is low-maintenance, with no carbon brushes to replace.

Jungheinrich's advanced AC impulse controller technology provides stepless speed control via the drive switch and rollback protection on ramps. Travel parameters, including acceleration, speed and motor braking, are easily adjustable. The highly-efficient AC controller ensures excellent energy management and longer operating

times at any performance level.

The long, low mounted control handle maximizes the distance between the operator and the truck, ensuring the highest degree of security for the user at all times during normal operation. If space is at a premium, the standard crawl-speed button allows for maneuvering in tight areas with the handle in the vertical position.

A completely redeveloped control handle offers operators a unique, state-of-the-art design with a rocker switch. This ergonomically-arranged design allows the operator to raise and lower the forks with the handle in virtually any position, even when fully vertical at 90 degrees.

Key advantages include:

- Innovative, 1.1 kW (EJE 120) and 1.7 kW (EJE 225), 3-phase AC drive motor for powerful acceleration and excellent speeds
- Rugged chassis and load section for heavy-duty operation

- Brake is automatically applied when travel is not requested to prevent unintentional ramp rollback
- Redesigned forks for improved pallet entry
- Multiple pallet-entry options
- Integrated charger
- Shorter chassis for improved turning radius
- Optional 2" full color display
- ProTracLink for excellent stability
- Lowered battery cover height for improved visibility to fork tips
- 15.3% improvement over the previous generation model in steering effort for even smoother operation

Additionally, the tiller head features an IP rating of 65, effectively sealing out dirt and moisture and prolonging component life.

JUNGHEINRICH®

Technical data

				Jungheinrich		Jungheinrich			
				EJE 120		EJE 120			
Characteristics	1.1	Manufacturer			small		medium		
	1.2	Model			electric		electric		
	1.3	Drive			walkie		walkie		
	1.4	Type of operation							
	1.5	Load capacity / rated load	Q	lbs kg	4,500	2,041	4,500	2,041	
	1.6	Load center distance	c	in mm	23.6	600	23.6	600	
	1.8	Load distance center (drive axle to fork)	x	in mm	37.7 ¹⁾	958 ¹⁾	37.7 ¹⁾	958 ¹⁾	
	1.9	Wheelbase	y	in mm	51.3 ¹⁾	1,302 ¹⁾	54.9 ¹⁾	1,394 ¹⁾	
	Weights	2.1	Service weight including minimum battery (see line 6.5)			lbs	kg	926	420
2.2		Axle loading – loaded, drive / load			lbs	kg	1,776 / 3,650	806 / 1,655	
2.3		Axle loading – unloaded, drive / load			lbs	kg	726 / 200	329 / 91	
Wheels, Chassis	3.1	Tires			PU / PU		PU / PU		
	3.2	Tire size, drive		in mm	9.1 x 2.8	230 x 70	9.1 x 2.8	230 x 70	
	3.3	Tire size, load		in mm	3.2 x 4.3	82 x 110	3.2 x 4.3	82 x 110	
	3.4	Additional wheels – dimensions ³⁾			in mm	3.9 x 1.6	100 x 40	3.9 x 1.6	100 x 40
	3.5	Wheels – number, drive / load (x = driven wheels)			1x+2		1x+2		
	3.6	Tread, front	b ₁₀	in mm	20	510	20	510	
	3.7	Tread, rear	b ₁₁	in mm	14.3	363	14.3	363	
Dimensions	4.4	Maximum fork height (MFH)			h ₃	in mm	8.25	210	
	4.9	Handle height in drive position, minimum / maximum			h ₁₄	in mm	29.5 / 48.7	750 / 1,237	
	4.15	Lowered fork height			h ₁₃	in mm	3.23	82	
	4.19	Overall length			l ₁	in mm	64.4	1,636	
	4.20	Length to fork face, headlength			l ₂	in mm	19.1	486	
	4.21	Overall width			b ₁	in mm	28.3	720	
	4.22	Fork dimensions, thick / width			s / e / l	in mm	2.2 / 6.8 / 45.3	55 / 172 / 1,150	
	4.25	Overall width across forks			b ₅	in mm	21.1	535	
	4.32	Ground clearance, center of wheelbase			m ₂	in mm	1.1	30	
	4.34.1	Aisle width (for pallets 40" x 48" crossways) ³⁾			Ast	in mm	70.4 ¹⁾	1,787 ¹⁾	
4.34.2	Aisle width (for pallets 48" x 40" lengthways) ³⁾			Ast	in mm	76.5 ²⁾	1,944 ²⁾		
4.35	Turning radius			W _a	in mm	58.4 ¹⁾	1,483 ¹⁾		
Performance	5.1	Travel speed, loaded / unloaded			mph	kph	3.5 / 3.5	5.6 / 5.6	
	5.2	Lift speed, loaded / unloaded			ft / s	m / s	0.13 / 0.13	0.04 / 0.04	
	5.3	Lowering speed, loaded / unloaded			ft / s	m / s	0.16 / 0.13	0.05 / 0.04	
	5.8	Maximum gradeability, loaded / unloaded			%		8 / 20		
	5.10	Service brake					electric		
Motors	6.1	Drive motor (rating S ₂ 60 minutes)			kW		1.1		
	6.2	Lift motor rating at S ₃ 10%			kW		1.2		
	6.3	Battery according to DIN 43531/35/36 A, B, C, no.					no. B		
	6.4	Battery voltage			V/Ah		24 / 150		
	6.5	Battery weight, minimum			lbs	kg	333	151	
	6.6	Energy consumption according to DIN EN 16796			kWh/h		0.34		
	6.7	Turnover output according to VDI 2198			US t/h	t/h	128	117	
	6.8	Turnover efficiency according to VDI 2198			kWh/h		0.7		
Other	10.7	Sound pressure level at the operator's seat			dB (A)		61		

- 1) Dimensions are published with raised forks. Lowering the forks results in +2.2 inches added.
2) Dimensions are published with raised forks. Lowering the forks results in +1.14 inches added.
3) Measurements include 7.9" safety clearance calculated for maneuvering

This specification sheet only provides technical values for the standard truck. Non-standard tires, different masts, additional equipment, etc., could produce other values. Rights reserved for technical changes and improvements.

EJE 120 / 225

1.1	Jungheinrich	
1.2	EJE 225	
	medium	
1.3	electric	
1.4	walkie	
1.5	6,000	2,721
1.6	23.6	600
1.8	37.7 ¹⁾	958 ¹⁾
1.9	56.1 ¹⁾	1,423 ¹⁾
2.1	1,193	541
2.2	2,694 / 4,497	1,222 / 2,040
2.3	926 / 267	420 / 121
3.1	PU / PU	
3.2	9.1 x 2.8	230 x 70
3.3	3.2 x 4.3	82 x 110
3.4	3.9 x 1.6	100 x 40
3.5	1x+2	
3.6	20	510
3.7	14.3	363
4.4	8.25	210
4.9	29.5 / 48.7	750 / 1,237
4.15	3.23	82
4.19	69.3	1,760
4.20	24.0	610
4.21	28.7	728
4.22	2.2 / 6.8 / 45.3	55 / 172 / 1,150
4.25	21.1	535
4.32	1.1	30
4.34.1	72.2 ¹⁾	1,833 ¹⁾
4.34.2	80.2 ²⁾	2,036 ²⁾
4.35	63.1 ¹⁾	1,604 ¹⁾
5.1	3.5 / 3.5	5.6 / 5.6
5.2	0.16 / 0.23	0.05 / 0.07
5.3	0.16 / 0.13	0.05 / 0.04
5.8	8 / 20	
5.10	electric	
6.1	1.7	
6.2	2.2	
6.3	no. B	
6.4	24 / 250	
6.5	485	220
6.6	0.37	
6.7	163	
6.8	0.82	
10.7	70	

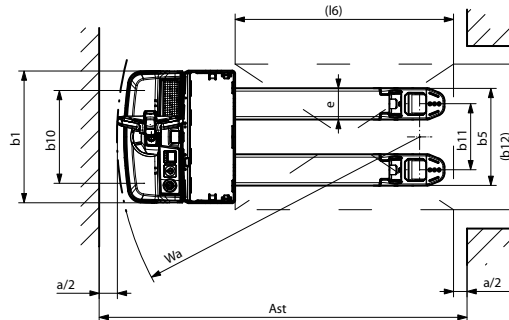
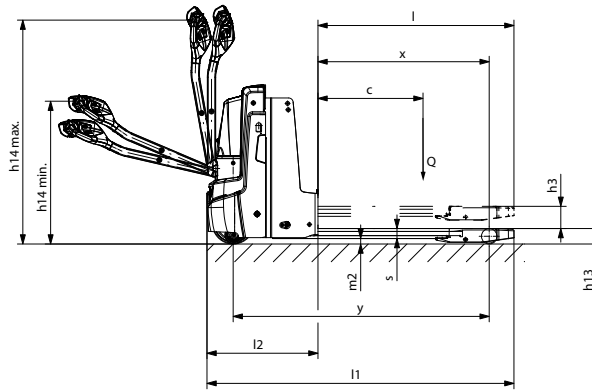
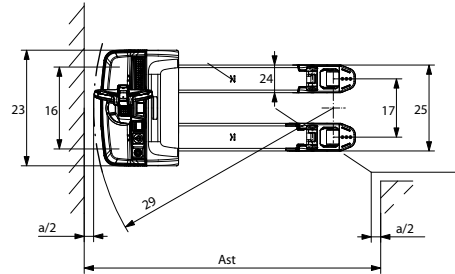
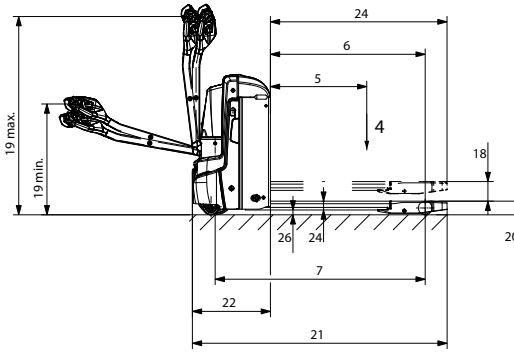

Note: Equipping this model (these models) with a power source (e.g. Lithium-ion, Hydrogen Fuel cell, etc.) that has not been previously approved by the factory is considered a modification. Per OSHA 1910.178 and ANSI/ITSDF B56.1, please consult with your factory representative prior to installing any non-OEM power source that has not been previously approved.

The Jungheinrich Advantage

Innovative 3-phase AC technology

Jungheinrich proprietary 3-phase AC motor technology provides increased efficiency and reduced operating costs. The following advantages maximize uptime and productivity:

- Outstanding efficiency due to excellent energy management.
- Powerful acceleration even with a full-rated load.
- Top speed of 3.5 mph with a fully-rated load.
- Quick directional changes without hesitation.

Powerful due to innovative 3-phase technology

- No carbon brushes or commutators to replace, resulting in reduced maintenance requirements.
- 2-year warranty on drive motor.

Long operating times

Battery capacities up to 250 Ah provide long operating times.

- Optional integrated charger for standard battery to max of 400 Ah and for maintenance free battery max of 300 Ah.

24V 110 Ah Lithium Ion

Lithium Ion package option (EJE 120) offers many advantages:

- On-board charger Li-ion (maximum charge time 3.5 hours).
- 50% battery charge after only 85 minutes of charging.
- Charge can be interrupted at any time without adverse effects.
- No need to add water.
- Maintenance-free.
- Long service life.

Excellent stability

- Optional "ProTracLink" caster wheel system, linked via a cushioned torsion bar, distributes stabilizing forces based on travel conditions (i.e. evenly across all wheels during straight travel; concentrated on the outer support when turning the wheel).



Ergonomic control handle

Multi-function control handle

The redeveloped tiller handle adjusts to different operator requirements:

- Clearly marked operator controls and rocker switches allow for intuitive operation in any handle position.
- Crawl-speed button is positioned on the back of the control handle for quick access and ease of operation when the handle is in the vertical position.

Rugged construction for tough applications

- Chassis made of high quality, 0.3 inch thick steel.
- Rolled steel forks for excellent durability.
- 3 degree beveled down forks for better pallet entry.
- Optimal cross-pallet entry supported by standard fork marks which also helps to avoid pallet damage.
- Pallet exit rollers for easy pallet exiting.
- Fork tip marks for improved guidance.

Well informed at any time

- Standard key switch with BDI.
- Optional 2-inch display with BDI, driving programs, speed indicator and option settings.
- Access system with key, easyACCESS (soft-key) or PinCode.

Additional features

- Shorter, more compact chassis for better maneuverability.
- Most versatile truck in its class with optimized load frame and 3-degree beveled fork tips.
- Redesigned lowered battery box for improved visibility.
- Streamlined cables and wires for improved maintenance and serviceability.
- Ability to program truck to 3 different performance levels.
- Speed control tiller for reduced speed in critical tiller angles.
- Unit reflectors.
- Energy saving option to shut down after 5 minutes of non-usage to conserve energy.
- Redesigned wheels for greater stability.
- New pallet entry discs rotate to effectively grab the bottom deck board and pull the forks forward into the pallet.
- Optional freezer package available on the EJE 120.

Built in compliance with ANSI/ITSDF B56.1 design specifications for Type E industrial trucks with Type E battery at time of manufacture.

Parts when you need them*

Jungheinrich's Parts Fast or Parts Free Guarantee ensures next-business day delivery by 5:00 PM of all Jungheinrich parts in the United States, or they're free, including freight. For customers in Canada and Mexico, the guarantee ensures shipping of parts within 24 hours from the time the order was placed by the dealer. See your local Jungheinrich dealer for program details.

* Programs may be subject to change without notice and may vary by region. Please ask your local Jungheinrich dealer for complete terms and conditions.