



# PANTOGRAPH REACH TRUCK

3,000-4,500 LB CAPACITY

A NEW LEVEL OF PERFORMANCE IS WITHIN YOUR REACH



# ROBUST AND EFFICIENT

STATE-OF-THE-ART TECHNOLOGY SAVES ENERGY AND TIME FOR ADVANCED PRODUCTIVITY.



## Industry-Leading Run Times:

The ESR and EDR series of reach trucks has the ability to run up to two shifts on one battery charge, leading to significant operational profitability. All major components – software, motors and controllers – are designed into one synchronous, advanced system for superior energy efficiency, productivity and speed.

## Dynamic Lift Speeds:

Built to efficiently move product, this series of reach trucks can reach exceptional lift and travel speeds without compromising on control. The reach truck's hydraulic system reaches lifting speeds of up to 165 feet per minute – one of the fastest in the industry - helping your operators move more product in less amount of time.

## Advanced Brake Performance:

The ESR / EDR series uses advanced regenerative braking, which puts energy back into the battery when the truck slows down. This intuitive design also requires fewer parts and less maintenance. All of these features result in longer run times while maintaining consistent performance levels for even greater productivity and reduced maintenance costs.

## Sealed Components For Greater Reliability:

These reach trucks feature sealed components for added protection in severe conditions, such as cooler or freezer applications, against dust and moisture. Sealed components offer greater reliability and require less maintenance over time, lowering your overall cost of operation today and in the future.

- Runs up to two shifts on one battery charge\*
- Dynamic lift speeds – up to 165 ft. / minute
- Efficient design, advanced AC technology
- Lower total cost of ownership

The reliability and dependability of the ESR and EDR series delivers the performance that your operation requires.

## Outstanding Performance, Exceptional Value:

Mitsubishi Forklift Trucks developed the ESR and EDR series of reach trucks to deliver superior performance – at an exceptional value. With its advanced AC technology, this series is designed to reach new heights quickly and efficiently for greater productivity, shift after shift.



\* in most applications



### **Advanced Technology and Performance**

AC technology is integrated into the reach truck design for increased efficiency and productivity.

Your business will benefit from:

- Low energy consumption
- Longer run times
- Powerful acceleration
- Excellent lift speeds
- Efficient energy management
- Smooth directional changes
- Less maintenance

Combined, these benefits lead to a lower cost of ownership and a better bottom line.

### **Lithium-Ion Availability:**

- Greater power efficiency
- Run for 24 hours a day, 7 days a week with opportunity charging
- Zero battery maintenance
- No watering
- No more battery exchanges
- No gas emissions, odor or acidification
- No special charging areas or equipment needed
- Longer lasting life cycles (up to 3,000)
- 5-year warranty on batteries
- 2-year warranty on chargers



Ask your local dealer about additional performance and operator comfort options.

# METICULOUS CONTROL.

ENHANCED DESIGN AND STABILITY KEEP OPERATORS IN CHARGE.



- Excellent stability at high lift heights
- Precise operation with intuitive controls
- Adjustable performance settings

These features help keep your operators productive and focused, shift after shift.

## Designed For Stability From The Ground Up

The ESR / EDR series delivers exceptional stability that is unmatched at high lift heights.

- ① Rigid mast design provides excellent load stability and smooth pantograph performance
- ② Suspended articulating drive axle helps to evenly spread loading forces between the drive and caster wheels
- ③ Dual-articulating load wheels provide more contact area to the floor, helping to more evenly distribute load forces at very high lift heights

The result? Greater operator confidence and less risk of product damage.



Intuitive control handle for precise positioning



Ergo-cushioned floor for added support



Electronic power steering for easy maneuvering

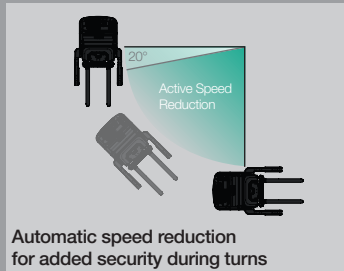

Automatic speed reduction for added security during turns

### Exceptional Comfort And Control:

- Electronic power steering makes maneuvering in and out of aisles easy, while allowing the operator to experience less fatigue.
- Spacious operator compartment with surrounding padding and sit-down operation capability on the wide chassis models helps to keep operators fresh.

### Additional Features:

- Automatic speed reduction – reduces travel speed when the truck turns past a predetermined angle overriding operator speed commands.
- Automatic parking brake – The electromagnetic brake is mounted to the top of the drive motor and is only deactivated when the operator commands travel. It is automatically set when power is turned off or the operator steps off the traction pedal.



### Informative Display:

Through one easy-to-read screen, operators can quickly view key indicators, such as the current battery charge level, hour meter and performance modes.



### Excellent Visibility:

Operators experience confidence with this series' design. Features such as wide channel spacing, stacked hydraulic hosing and a robust overhead guard with angled bars provide excellent visibility to the load and the surrounding area.

CHARACTERISTICS			ESR15N2		ESR18N2		ESR20N2		ESR23N2	
1	Type		Single Reach		Single Reach		Single Reach		Single Reach	
2	Power voltage		36		36		36		36	
3	Capacity at rated load center	lb kg	3,000	1,400	3,500	1,600	4,000	1,810	4,500	2,040
4	Capacity load center – distance from fork face	in mm	24	600	24	600	24	600	24	600
<b>DIMENSIONS</b>										
5	Maximum fork height	in mm	450	11,430	450	11,430	450	11,430	450	11,430
6	Free fork height	in mm	59	1,500	59	1,500	59	1,500	59	1,500
7	Fork width	in mm	3.9	100	3.9	100	3.9	100	3.9	100
8	Fork thickness	in mm	1.6	40	1.6	40	1.6	40	1.6	40
9	Fork spacing - out-to-out minimum	in mm	12	305	12	305	12	305	12	305
10	Fork spacing - out-to-out maximum <sup>1)</sup>	in mm	31.5	802	31.5	802	31.5	802	31.5	802
11	Tilt angle - forward / backward	deg	3° / 4°		3° / 4°		3° / 4°		3° / 4°	
12	Mast width <sup>2)</sup>	in mm	30.2	766	30.2	766	32.2	816	32.2	816
12a	Reach stroke		24	610	24	610	24	610	24	610
13	Baseleg opening	in mm	33 - 49	839 - 1,245	33 - 49	839 - 1,245	33 - 49	839 - 1,245	33 - 49	839 - 1,245
14	Baseleg width <sup>3)</sup>	in mm	5.5	139.5	5.5	139.5	5.5	139.5	5.5	139.5
15	Overall length	in mm	73.4	1,864	75	1,906	75	1,906	75	1,906
16	Length to fork face	in mm	51.9	1,317	54	1,371	54	1,371	54	1,371
17	Overall chassis width	in mm	41.5	1,054	41.5	1,054	41.5	1,054	41.5	1,054
18	Overall lowered height	in mm	107	2,720	107	2,720	107	2,720	107	2,720
19	Overall height to top of overhead guard	in mm	95	2,413	95	2,413	92.5	2,349	92.5	2,349
20	Overall height with extended mast	in mm	290	7,370	290	7,370	290	7,370	290	7,370
21	Step height	in mm	9.6	245	9.6	245	9.6	245	9.6	245
22	Battery roller height	in mm	6.7	171	6.7	171	6.7	171	6.7	171
23	Minimum outside turning radius	in mm	68.74	1,746	70.74	1,797	70.74	1,797	70.74	1,797
24	Minimum aisle - 90° stack - zero clearance	in mm	Please consult your Mitsubishi forklift truck dealer							
<b>PERFORMANCE</b>										
26	Grade clearance <sup>5)</sup>	in mm	0.6	15.5	0.6	15.5	0.6	15.5	0.6	15.5
27	Travel speed loaded/empty – standard <sup>6)</sup>	mph km/h	6.8 / 7.5	11.0 / 12.1	6.8 / 7.5	11.0 / 12.1	7.5 / 7.5	12.1 / 12.1	7.5 / 7.5	12.1 / 12.1
28	Travel speed loaded / empty – high performance <sup>6)</sup>	mph km/h	–	–	–	–	7.5 / 8.0	12.1 / 12.9	7.5 / 8.0	12.1 / 12.9
29	Lift speed loaded / empty (triplex) – standard	fpm m/s	100 / 128	0.51 / 0.65	100 / 128	0.51 / 0.65	75 / 120	0.38 / 0.60	75 / 120	0.38 / 0.60
30	Lift speed loaded / empty (triplex) – high performance	fpm m/s	–	–	–	–	90 / 160	0.45 / 0.80	90 / 160	0.45 / 0.80
31	Lower speed loaded / empty (triplex) – standard	fpm m/s	108 / 108	0.55 / 0.55	108 / 108	0.55 / 0.55	110 / 110	0.55 / 0.55	110 / 110	0.55 / 0.55
32	Lower speed loaded / empty (triplex) – high performance	fpm m/s	–	–	–	–	110 / 110	0.55 / 0.55	110 / 110	0.55 / 0.55
33	Gradeability - loaded / empty - maximum	%	9 / 9		9 / 9		9 / 9		9 / 9	
<b>WEIGHT</b>										
34	Truck weight - empty - without battery	lb kg	6,950	3,152	6,950	3,152	7,150	3,243	7,150	3,243
35	Battery weight - min	lb kg	1,600	730	1,600	730	2,000	910	2,000	910
36	Battery weight - max	lb kg	2,000	910	2,000	910	2,300	1,050	2,300	1,050
<b>CHASSIS</b>										
37	Chassis type (stand/sit)		Stand		Stand		Stand		Stand	
38	Wheelbase	in mm	59.5	1,511	61.5	1,562	61.5	1,562	61.5	1,562
39	Ground clearance - center of wheelbase	in mm	2.4	60	2.4	60	2.4	60	2.4	60
40	Ground clearance - lowest point at mast	in mm	2.4	60	2.4	60	2.4	60	2.4	60
41	Tire size - steer	in mm	13.5 x 5.5	343 x 140	13.5 x 5.5	343 x 140	13.5 x 5.5	343 x 140	13.5 x 5.5	343 x 140
42	Tire size - caster	in mm	7 x 4	180 x 100	7 x 4	180 x 100	7 x 4	180 x 100	7 x 4	180 x 100
43	Tire size - load wheels	in mm	5 x 3.62	127 x 92	5 x 3.62	127 x 92	5 x 3.62	127 x 92	5 x 3.62	127 x 92
44	Brake type		Electromagnetic Disc		Electromagnetic Disc		Electromagnetic Disc		Electromagnetic Disc	
<b>ELECTRICAL</b>										
45	Traction / pump / steer motor type		AC Induction		AC Induction		AC Induction		AC Induction	
46	Traction motor output (60 minute rating) – standard	hp kW	6.0	4.5	6.0	4.5	6.0	4.5	6.0	4.5
47	Traction motor output (60 minute rating) – high performance	hp kW	–	–	–	–	9.2	6.9	9.2	6.9
48	Pump motor output (5 minute rating)	hp kW	27.2	20	27.2	20	27.2	20	27.2	20
49	Steer motor output (60 minute rating)	hp kW	1.0	0.7	1.0	0.7	1.0	0.7	1.0	0.7
<b>OTHER</b>										
50	Battery maximum capacity - A/H (6 hour rating)		1,120		1,120		1,120		1,120	
51	Battery compartment length <sup>7)</sup>	in mm	14.25	362	16.25	413	16.25	413	16.25	413
52	Battery compartment width	in mm	38.42	976	38.42	976	38.42	976	38.42	976
53	Battery compartment height	in mm	31.65	804	31.65	804	31.65	804	31.65	804

1) Maximum fork spacing 27.5 inches (698 mm) with 33 inch BLO.

2) Out-to-out dimension across mast outer channels.

3) 5.9 inches (150 mm) on single reach chassis with MFH over 332 inches (8430 mm).

4) 7.3 inches (186 mm) on single reach chassis with mast MFH above 332 inches (8430 mm).

5) Reduce grade clearance by 1.5% with 18.25 inch (463 mm) battery compartment length or 21.25 inch (539 mm) battery compartment length vs. 16.25 inch (412 mm) length.

6) Maximum speed attainable, after break-in period, varies with travel direction, truck weight, rolling resistance, mast height, options and battery condition.

7) 21.25 inch (539 mm) battery compartment length standard on chassis with MFH over 332 inches (8430 mm).

Note: Equipping this model (these models) with a power source (e.g. Lithium-ion, Hydrogen Fuel cell, etc.) that has not been previously approved by the factory is considered a modification. Per OSHA 1910.178 and ANSI/ITSDF B56.1, please consult with your factory representative prior to installing any non-OEM power source that has not been previously approved.

	ESR23LN		EDR18N2		ESR18LN	
	Single Reach		Double Deep Reach		Single Reach	
	36		36		36	
3	4,500	2,040	3,500	1,580	3,500	1,600
4	24	600	24	600	24	600
5	450	11,430	450	11,430	450	11,430
6	59	1,500	59	1,500	59	1,500
7	3.9	100	3.9	100	3.9	100
8	1.6	40	1.6	40	1.6	40
9	14.2	360	12	305	14.2	360
10	32.5	825	31.5	802	32.5	825
11	3° / 4°		3° / 4°		3° / 4°	
12	32.5	825	32.2	816	32.5	825
12a	24	610	42	1,067	42	1,067
13	33 - 49	839 - 1,245	33 - 49	839 - 1,245	33 - 49	839 - 1,245
14	5.5	139.5	5.5	139.5	5.5	139.5
15	77.4	1,967	75	1,906	79.4	2,018
16	56.0	1,422	54	1,371	63.3	1,607
17	48	1,220	41.5	1,054	48	1,220
18	107	2,720	107	2,720	107	2,720
19	92.5	2,349	92.5	2,349	92.5	2,349
20	290	7,370	290	7,370	290	7,370
21	9.8	250	9.6	245	9.8	250
22	7	178	6.7	171	7	178
23	73.1	1,858	70.74	1,797	73.1	1,858
24	Please consult your Mitsubishi forklift truck dealer					
26	-	14	0.6	15.5	-	14
27	-	-	7.5 / 7.5	12.1 / 12.1	-	-
28	7.5 / 8.0	12.1 / 12.9	7.5 / 8.0	12.1 / 12.9	7.5 / 8.0	12.1 / 12.9
29	-	-	75 / 120	0.38 / 0.60	-	-
30	90 / 165	0.45 / 0.80	90 / 160	0.45 / 0.86	90 / 165	0.45 / 0.86
31	-	-	110 / 110	0.55 / 0.55	-	-
32	110 / 110	0.55 / 0.55	110 / 110	0.55 / 0.55	110 / 110	0.55 / 0.55
33	9 / 10		9 / 9		9 / 10	
34	7,050	3,200	7,500	3,402	7,400	3,350
35	2,000	910	2,000	910	2,000	910
36	2,300	1,050	2,300	1,050	2,300	1,050
37	Sit / Stand		Stand		Sit / Stand	
38	62.9	1,597	61.5	1,562	62.9	1,597
39	2.4	61	2.4	60	2.4	61
40	2.4	61	2.4	60	2.4	61
41	13.5 x 5.5	343 x 140	13.5 x 5.5	343 x 140	13.5 x 5.5	343 x 140
42	7 x 4	180 x 100	7 x 4	180 x 100	7 x 4	180 x 100
43	5 x 3.62	127 x 92	5 x 3.62	127 x 92	5 x 3.62	127 x 92
44	Electromagnetic Disc		Electromagnetic Disc		Electromagnetic Disc	
45	AC Induction		AC Induction		AC Induction	
46	9.2	6.9	6.0	4.5	9.2	6.9
47	-	-	9.2	6.9	-	-
48	27.2	20	27.2	20	27.2	20
49	1.0	0.7	1.0	0.7	1.0	0.7
50	1,120		1,120		1,120	
51	16.25	413	16.25	413	16.25	413
52	38.86	987	38.42	976	38.86	987
53	34.17	868	31.65	804	34.17	868

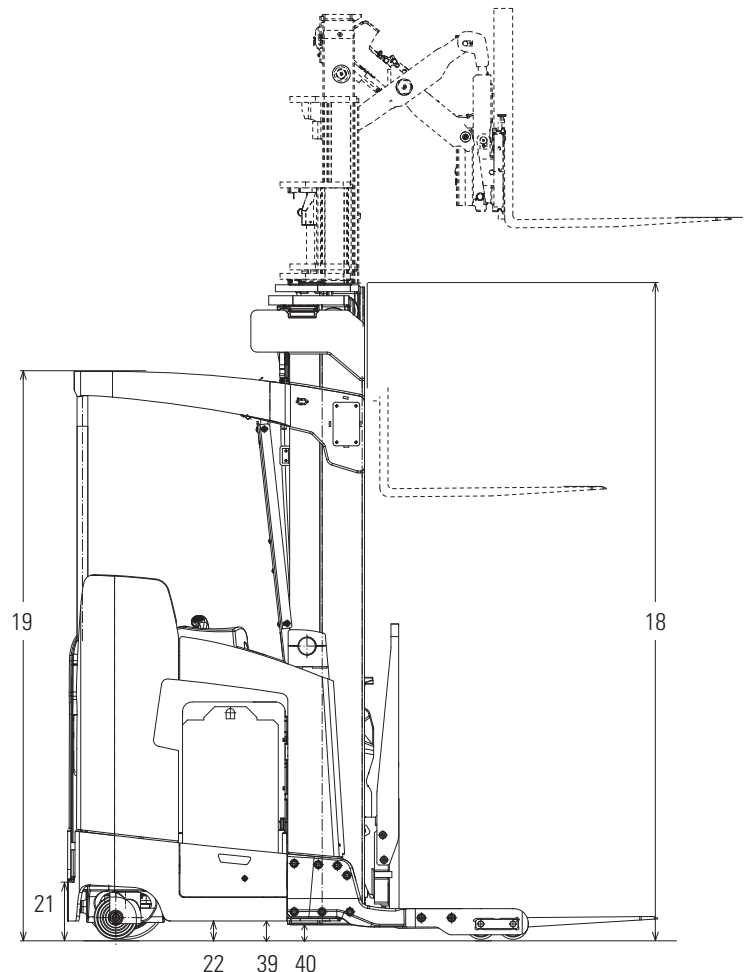
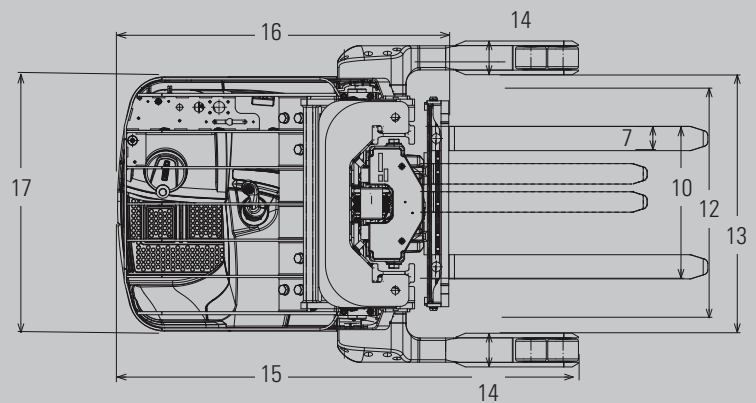

## SAFETY STANDARDS

These trucks meet American National Standards Institute/Industrial Truck Standards Development Foundation, ANSI/ITSDF B56.1. UL-Classified by Underwriters Laboratories, Inc., as to fire and electric shock hazard only; Type E, EE (optional), Industrial Trucks. Users should be aware of, and adhere to, applicable codes and regulations regarding operator training, use, operation and maintenance of powered industrial trucks, including:

- ANSI/ITSDF B56.1.
  - NFPA 505, fire safety standard for powered industrial trucks - type designations, areas of use, maintenance and operation.
  - Occupational Safety and Health Administration (OSHA) regulations that may apply.
- Specifications, equipment, technical data, photos and illustrations based on information at time of printing and subject to change without notice. Some products may be shown with optional equipment.

# ESR15N2-EDR18LN

3,000-4,500 LB CAPACITY PANTOGRAPH REACH TRUCK

## Delivering Exceptional Value

### More Than 296,000 Parts To Keep You Running

Mitsubishi Forklift Trucks offers several parts programs, all designed to bring you top performance and convenience for your material handling needs. Contact your local dealer to put our services to work for you.

### Support To Fit Your Operation

Find out why more companies are relying on Mitsubishi forklift truck dealers to keep their fleet operating at top performance. Our efficiency provides customers with a better return on investment, and qualified service technicians, diverse parts inventory and unparalleled selection of service options can help reduce your total cost of ownership.

### Extensive Dealer Network

The Mitsubishi forklift truck dealer network is dedicated to finding the right forklift solution for your business. With more than 300 dealer locations, you can rely on your local dealer to provide the service you need when you need it most.



Manufactured with superior quality and exceptional value, Mitsubishi forklift trucks are supported by an extensive dealer and field support network located throughout North and South America. Don't forget to ask your local Mitsubishi forklift truck dealer about details on factory retail programs, financing plans and additional options and dealer services like planned maintenance and operator training.